



# HYBRIDFLO™

## AUTOMATIC SOAP DISPENSER SYSTEMS

Model  
**ASD-100**

### Description

Sensor Operated, Gear Motor Driven, Chrome Plated Brass Counter Mount Automatic Soap Dispenser System

### Specifications

- Chrome Plated Solid Brass Spout (Standard)
- Gear Motor Drive
- Hands Free Infrared Sensor Activation
- Powered by Four (4) Alkaline D-Cell Batteries (not included)
- AC Power Adapter (Optional)
- Universal Refillable Soap Container (1600mL/ 54oz.)
- Viscosity: 100 - 3500 mPa.S
- Mount Through 1" (25mm) Diameter Hole in Lavatory or Countertop
- Auto Adjustable Activation Range
- Activation Indicator: Red Light on Sensor
- Low Battery Indicator: Solid Red Light on Sensor
- Low Soap Indicator: Blue Flashing Light on Sensor
- Reset Button Automatically Resets Low Refill Light and Primes New Soap Refill
- Optional Spacer (Included)
- Easy Installation
- ADA Compliant



### Warranty

3 Years



ADA Compliant

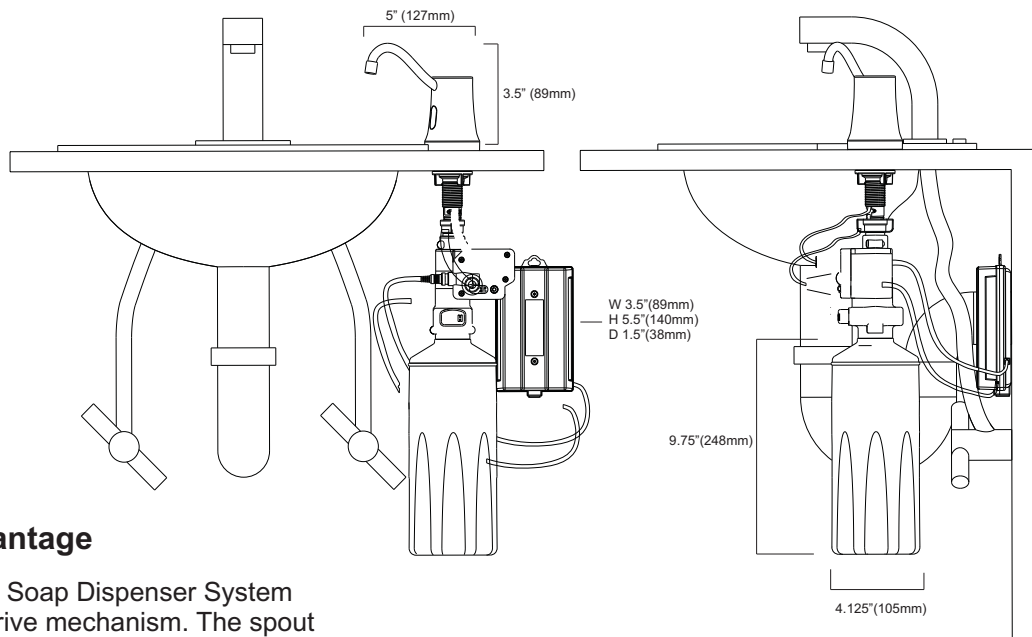

### The HYBRIDFLO™ Advantage

The HYBRIDFLO™ Automatic Soap Dispenser System operates using a gear motor drive mechanism. The spout is built of high quality solid brass. The design of the control unit allows for easy installation and conceals all mechanical and electrical components. An easy universal refillable soap container makes the HYBRIDFLO™ Automatic Soap Dispenser System very economical.

### Architect/Engineer Approval

Job Name	_____
Date	_____
Model Specified	_____
Quantity	_____
Variations Specified	_____
Customer/Wholesaler	_____
Contractor	_____
Architect	_____